

Eva

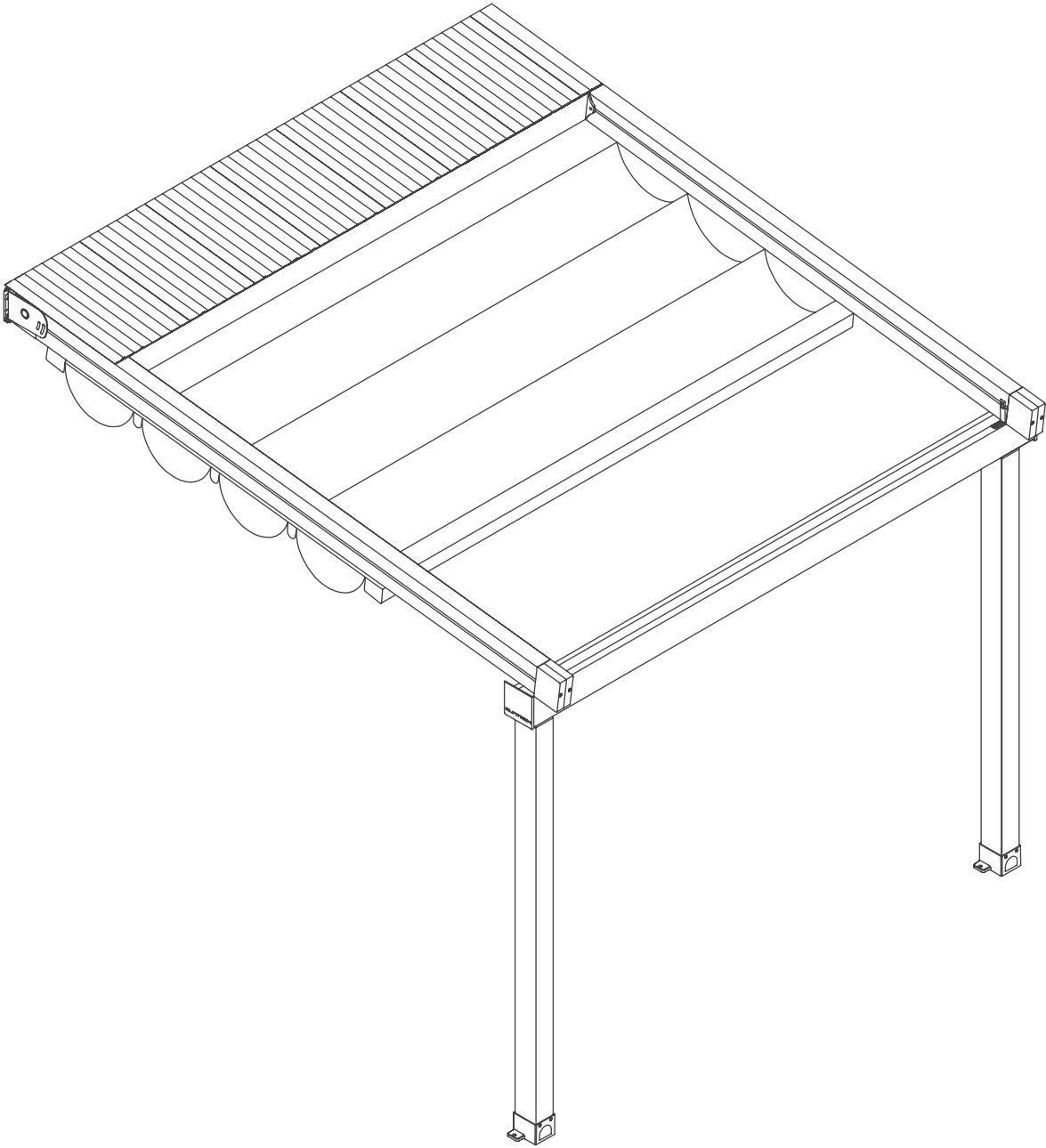

## Eva retractable pergola system

The EVA retractable pergola system provides an elegant outdoor covering to allow outdoor areas to be used in even the worst of weather conditions. The system offers a wind rating up to Beaufort class 11 (up to 117km/h).

The system is manufactured to size using high grade 6063 extruded aluminium profiles finished with thermosetting powder coating which provides superior overall performance for exterior product applications. All bolts, screws and pins are high grade stainless steel to ensure extended system life.

The EVA rafter profiles (60mm x 125mm) have been designed with unique water guard side channels and allow for projection dimensions up to 6m per system. The width dimensions are customised according to site requirements and available in any size up to 13m. The EVA system offers up to 78sqm of protection with a touch of button but when required linking multiple systems is also possible and made easy by our patented storm channel joining system that ensures 100% waterproof join every time.

Remote controlled motorisation is provided by utilising European technology through a custom built direct drive motor system to ensure smooth and quick operation at 26RPM. The optional hi powered LED-TEC lighting system provides a practical touch of class and when coupled with a remote dimming controller allows the user to change the mood to suit the surrounding environment.

The heart of the system is driven by multiple Suntech F2 four wheeled slider carriages (each F2 slider carriage has a load limit of 600kgs) that incorporates a triple layer barrier system and works in conjunction with a timing belt that has been reinforced with multiple internal stainless steel cables to provide a pulling strength of over 966kg. This tension is applied to the fabric membrane to allow an angle of 6 degrees fall possible and ensure all water drains away.

The fire rated and 100% waterproof architectural membrane is available in a range of colours in both opaque and transparent that provides maximum stability and resistance to temperature, moisture and dirt. It does not shrink or bag, and the acrylic top coating makes it very easy to clean for years to come. When not in use the fabric is neatly retracted under the systems hood to provide protection from the elements when not required.

To ensure the highest level of protection Suntech systems focus on all the details, this is why all Suntech systems come standard finished with Stormguard soft touch edge seal on all parameters. Stormguard provides the ultimate protection against rain and draught intrusion around the outside of the system and is only available on our systems. Stormguards soft touch edge seal is produced from an extra soft & flexible rubber to ensure the best possible protection from the elements.

# Eva

## One Module

200 cm > 450 cm  
One Module with one motor & 2 rafters

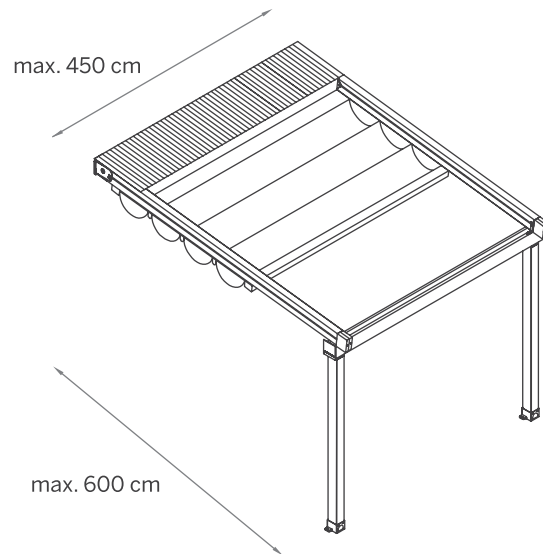

## Two Modules

450 cm > 900 cm  
Two Modules with one motor & 3 rafters

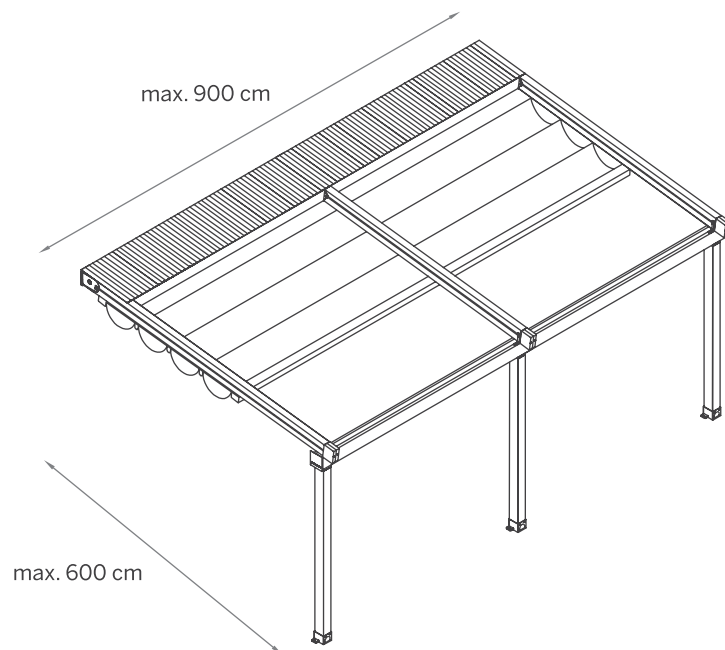

### Three Modules

900 cm > 1300 cm

Three Modules with one motor & 4 rafters

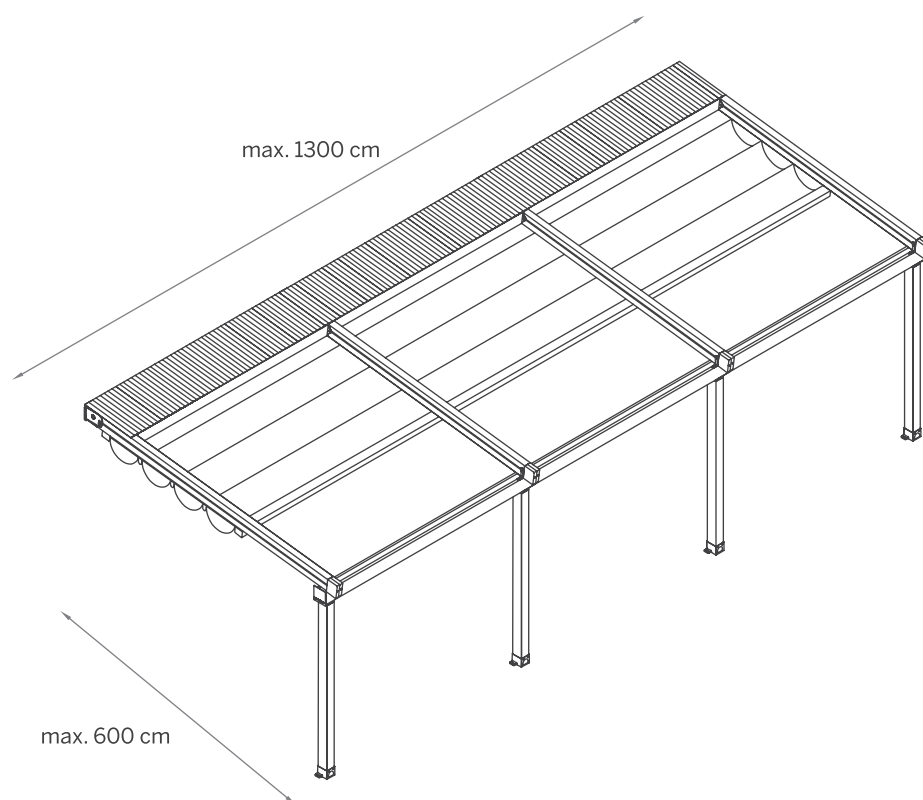

# Eva

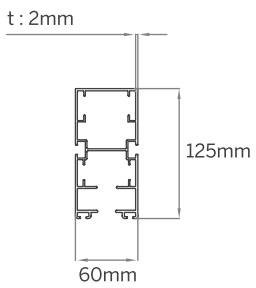
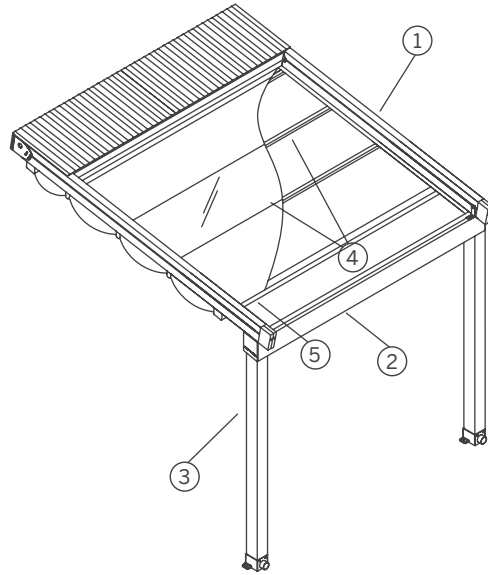

① Rafter

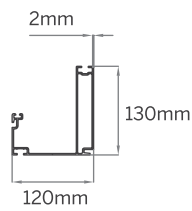

② Gutter

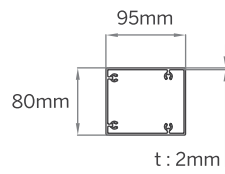

③ Post

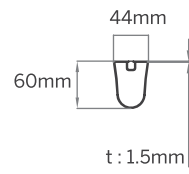

④ Fabric Support (Standart)

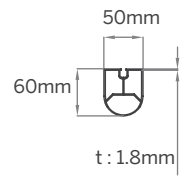

④ Fabric Support (HDD Lux)

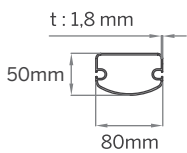

⑤ Puller Profile

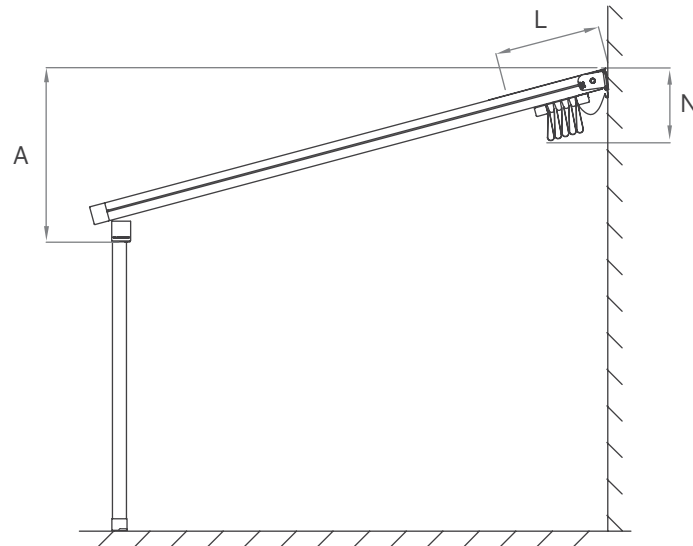

### Eva

|     | Fabric Height | Hood    | Fall       | Fab.Sup.Profiles |
|-----|---------------|---------|------------|------------------|
|     | (N*) mm       | (L*) mm | (A*,**) mm | pc*              |
| 300 | 417           | 672     | 625        | 7                |
| 350 | 409           | 811     | 685        | 9                |
| 400 | 424           | 881     | 745        | 10               |
| 450 | 437           | 950     | 805        | 11               |
| 500 | 449           | 1020    | 865        | 12               |
| 550 | 461           | 1089    | 929        | 13               |
| 600 | 472           | 1159    | 990        | 14               |

\* With min. inclination of 7°. Values can vary by other inclination values.

# Eva

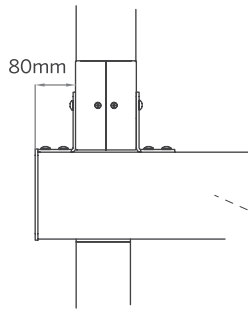

Type - A

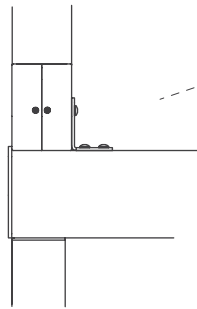

Type - B

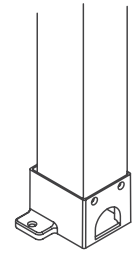
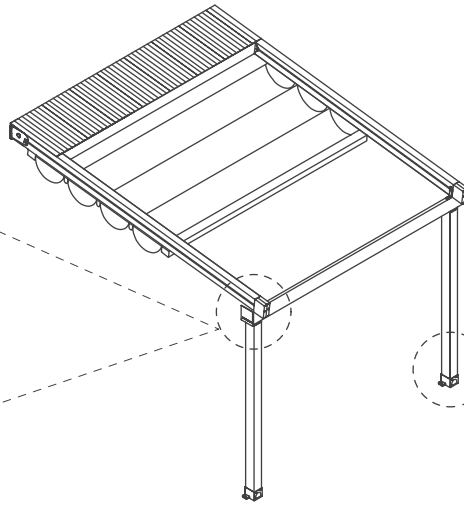

Type - A

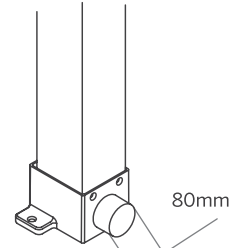

Type - B

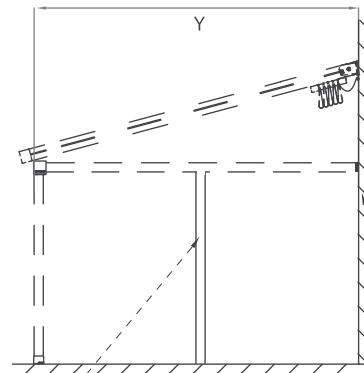
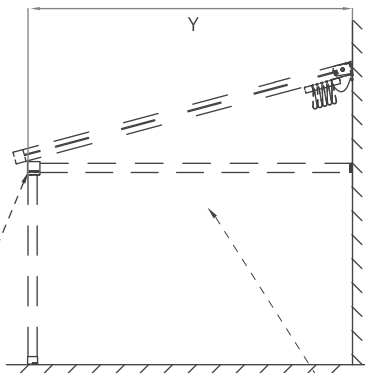
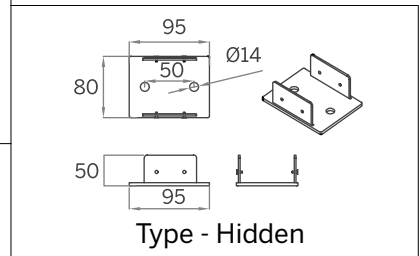
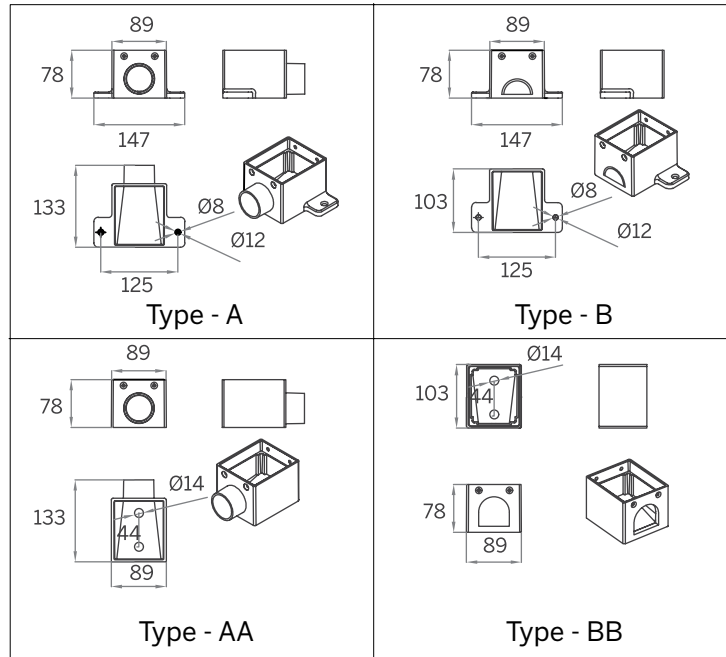

Gutter Connection

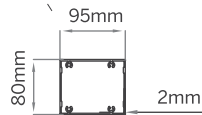

Side Rafter

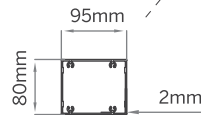

Support Column of Side Rafter



Wall Connection

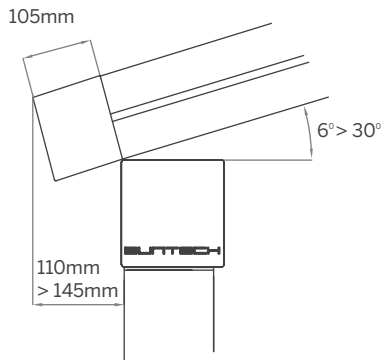
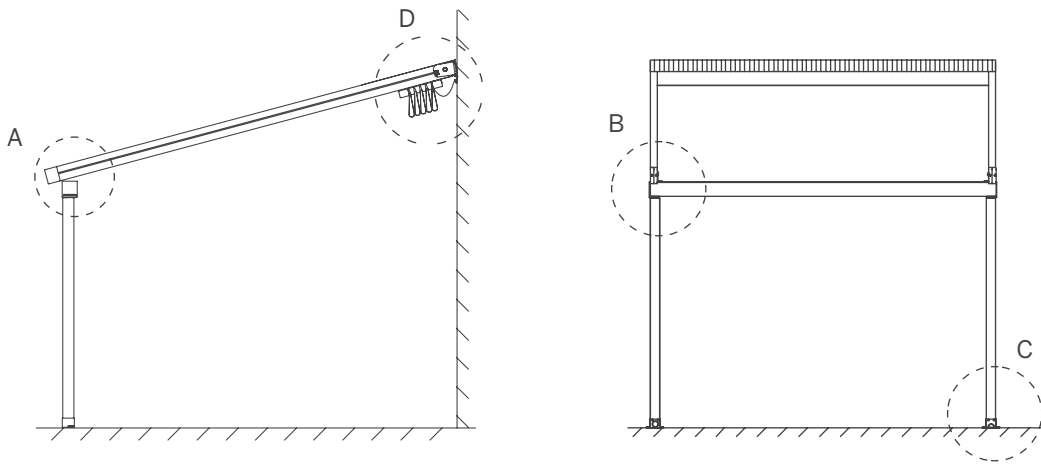

DETAIL A

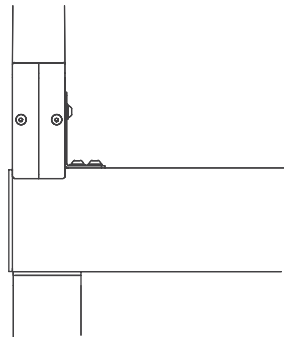

DETAIL B

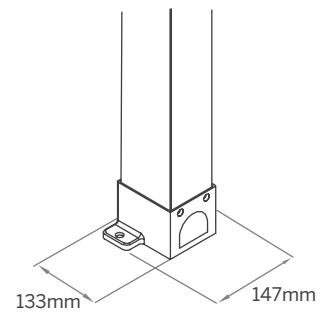

DETAIL C

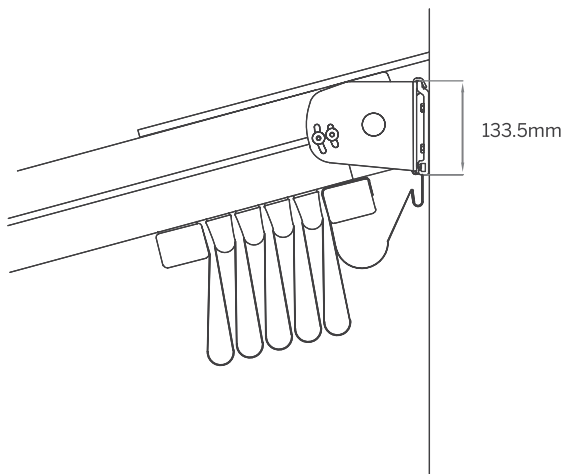

DETAIL D

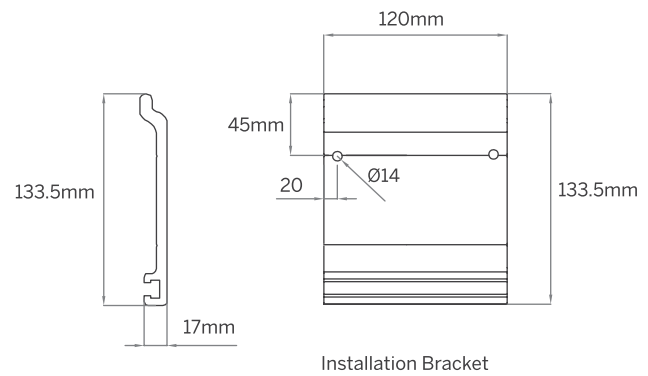

Installation Bracket



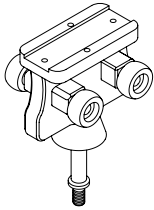

## F2 Four wheel slider

Four vertical rollers working together for perfectly smooth operation every time. The F2 four wheel system is proven to remove the jamming issue and can take loads of upto 600KG.

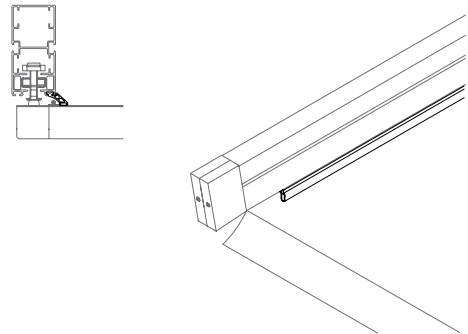

## Rafter stormguard edge seal

The rafter Stormguard edge seal stops water from dripping over the side of the system by providing a soft cushioning barrier along the side of the system.

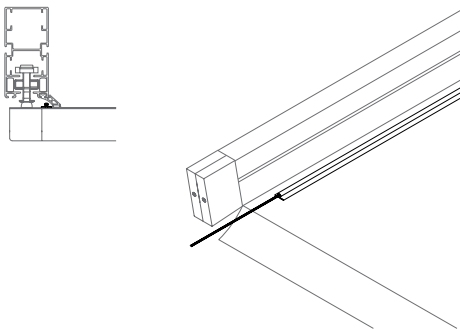

## Fabric anti-drop edge cord with electrical cable

The fabric anti-drip edge cord with integrated lighting electrical cable works in conjunction with the Stormguard edge seal to prevent any water leaks over the side of the system.

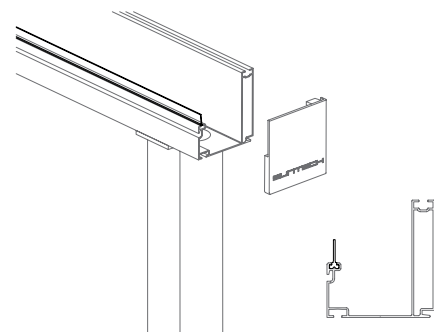

## Gutter stormguard seal

The Stormguard gutter seal provides a perfect seal to prevent water leaks along the front of the system from driving rain or splashing from the gutter.

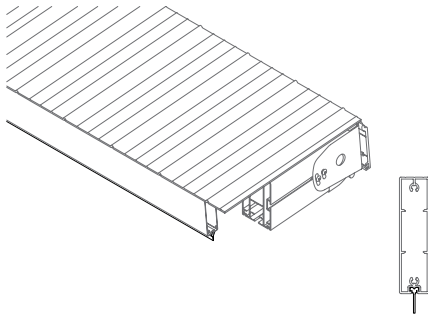

### Hood stormguard seal

The Stormguard hood seal provides the perfect seal to prevent driving rain & wind coming in under the hood profiles.

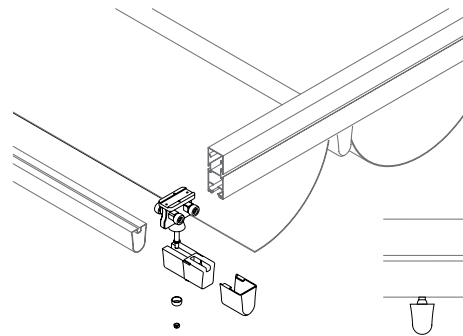

### F2 slider and fabric profile assembly

The system has been designed for ease of assembly to save time on installations and reduce the number of staff required.

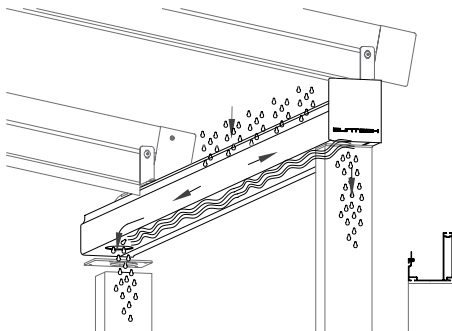

### Integrated gutter & internal drainage system

The integrated gutter system provides the perfect solution for water drainage.

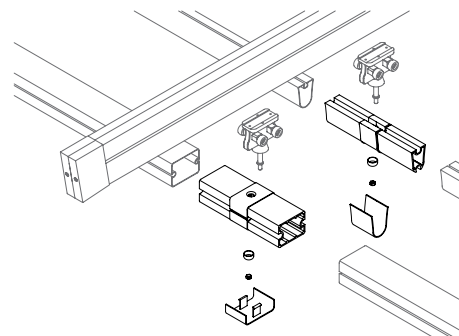

### Easy clip intermediate joints (for 2 & 3 module systems)

The Easy clip intermediate joints have been designed for ease of site assembly to save time and reduce the number of staff required.

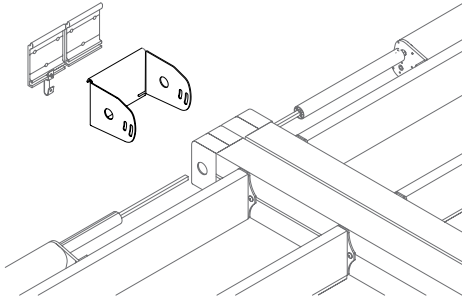

## Double rafter wall bracket kit

An advanced solution for installing two rafter's at once.

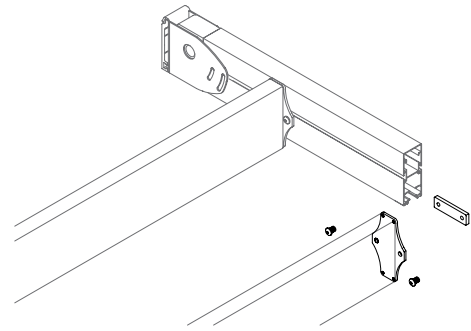

## Motorbox support & hood support profile easy installation

Each support profile is easy to install and simple to adjust at the time of installation.

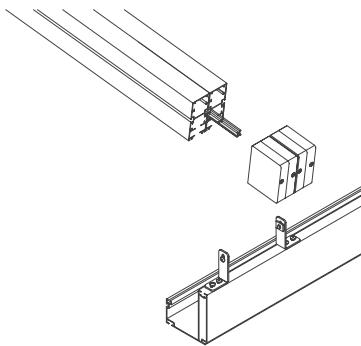

## Storm channel for joining system

The storm channel is patented solution for joining two systems side by side with a waterproof join.

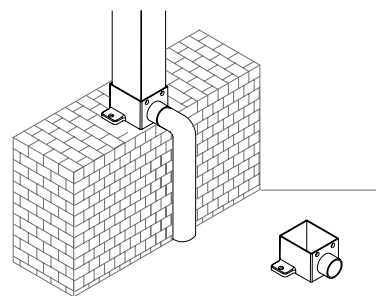

## Base plate with external spout

This base plate provides a water dispersal solution.

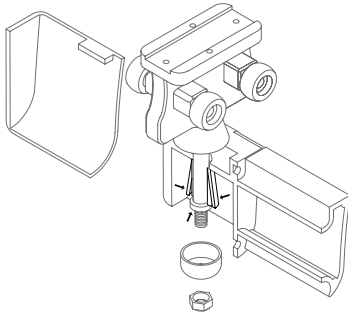

## F2 slider easy clip installation

The F2 system has been designed for ease of use, to save time on installations and reduce the number of staff required. Each F2 slider can take loads of upto 600KG once in place.

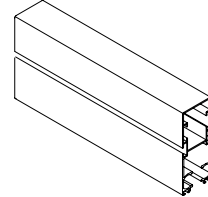

## Rafter profile with side channels for easy installation

The Suntech rafter profiles are designed with functional side channels for easy installation.

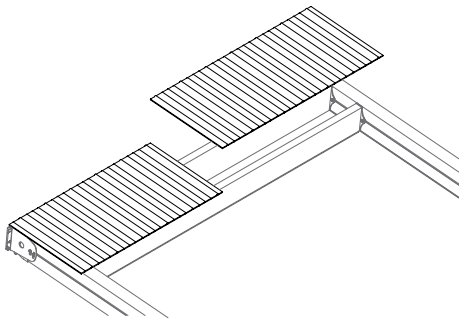

## Hood profile sheets

Suntech's hood profile sheets provide an attractive covering solution for the system when not in use. The low profile aesthetic design offers additional protection to the system with a chic touch.

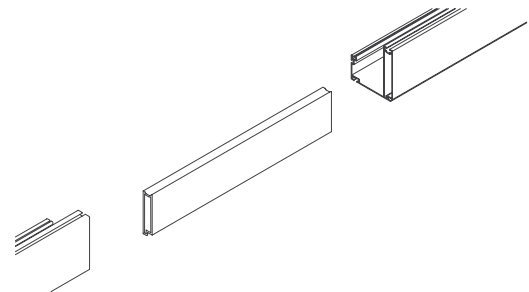

## Gutter profile joining bar

A smart solution for joining the gutter profiles.

# Eva

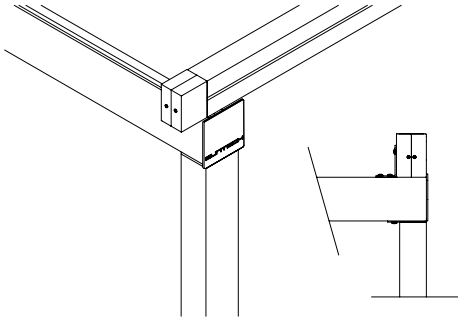

## Gutter flush with rafter

Gutter solution when the system is installed next to a wall or no overhang of the gutter is required.

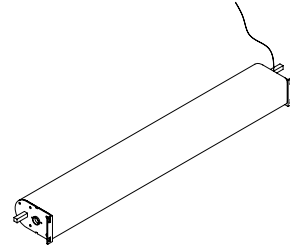

## Compact 26rpm direct drive motor box

The Suntech direct drive motor system is a quick and efficient system that drives all conveyor rafters at the same time. The low profile design also allows the fabric to be stored underneath the motor which saves additional space.

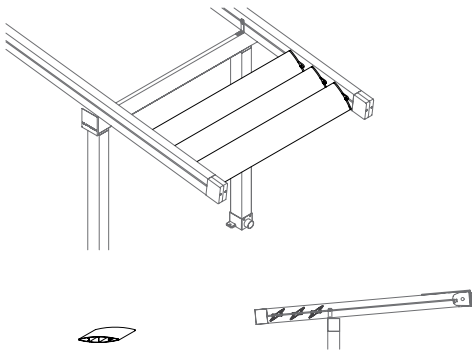

## Aerofoil Louvres

The addition of Aerofoil louvres can provide added shade when the system is closed.

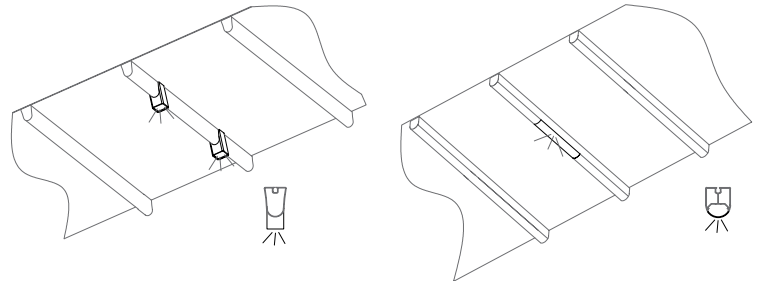

## LED-TECH high powered lighting

LED-TECH lighting is an integrated lighting solution that can be added to any Suntech system.

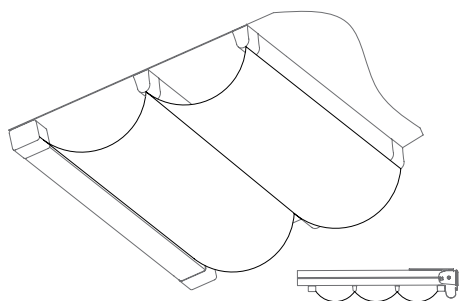

## Decorative fabric under layer

The second decorative fabric under layer of fabric can provide an elegant touch of design.

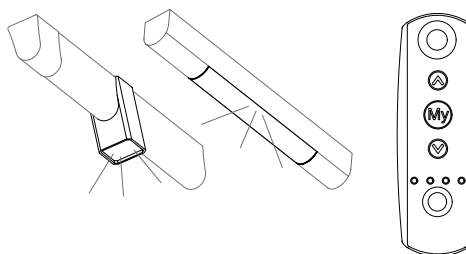

## LED-TECH dimmer setup

LED-TECH dimmer lighting is an integrated lighting solution that can be added to any Suntech systems.

# Eva

type I

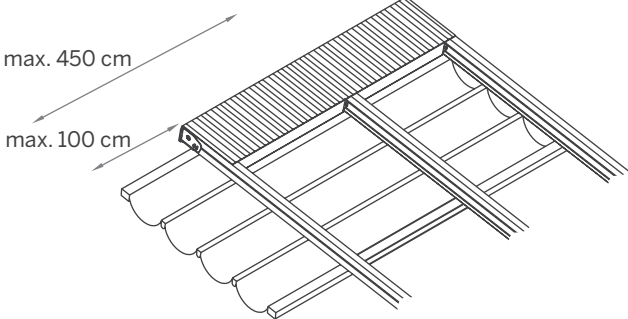

type II

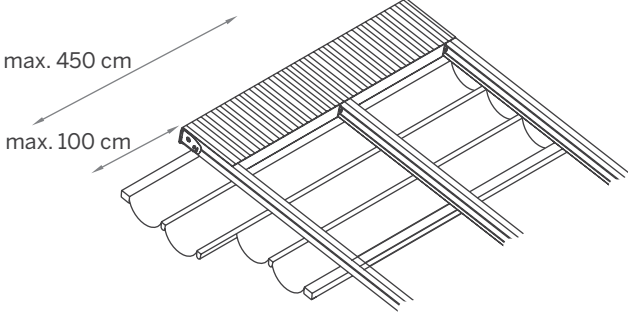

type III

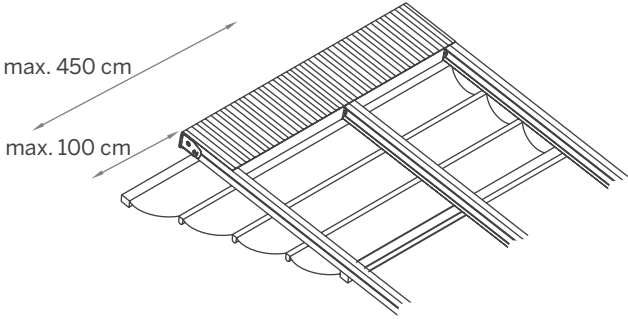

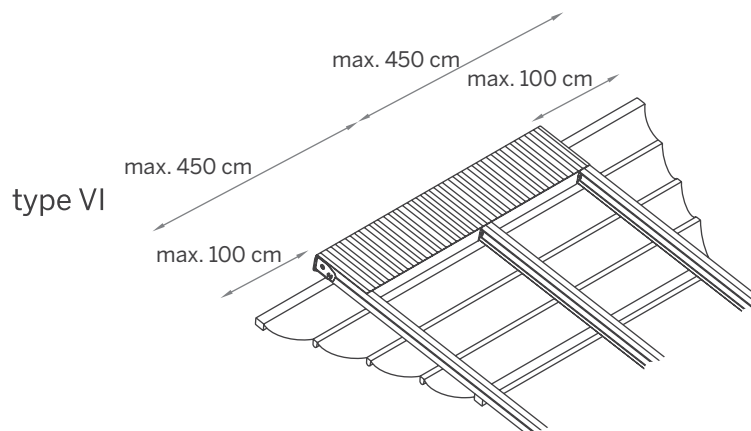
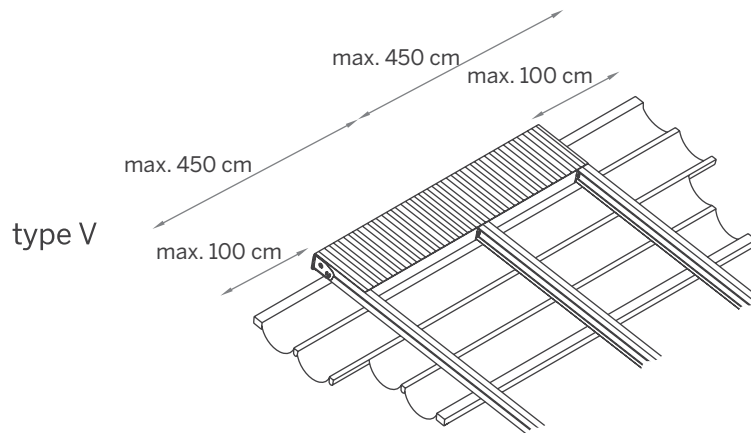
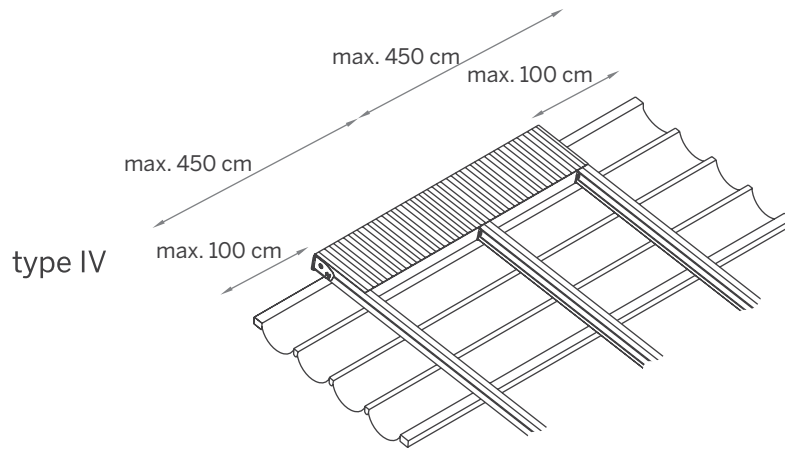

Each system is available with an optional overhang to allow the covered area to protrude past the rafter profile. Site specific overhang solutions such as stepped or wedge shapes are also an effective way to get maximum coverage for your areas.



## One Module

200 cm > 450 cm  
 One Module with one motor & 2 rafters

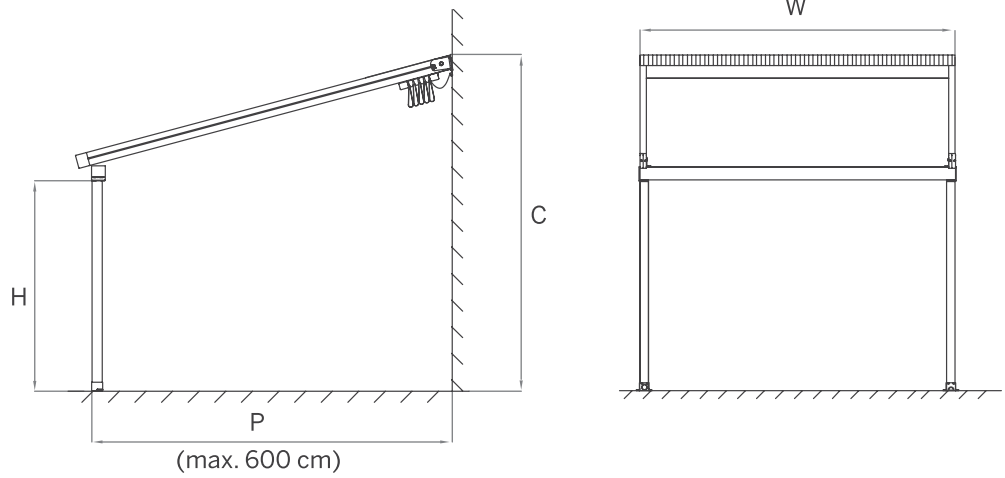

## Two Modules

450 cm > 900 cm  
 Two Modules with one motor & 3 rafters

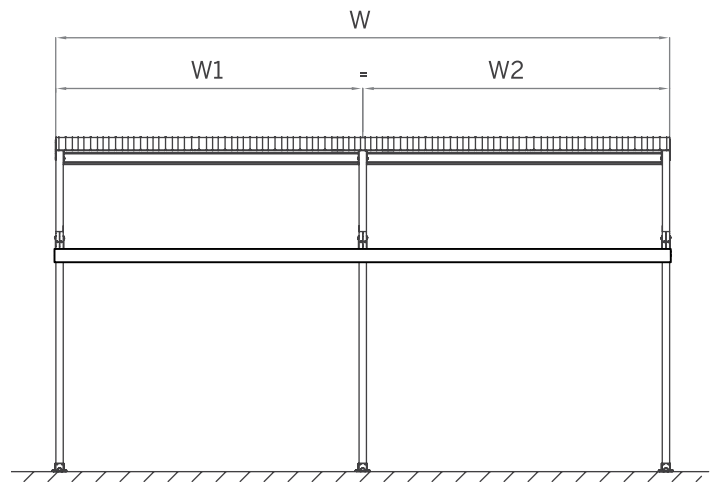

## Three Modules

900 cm > 1300 cm  
 Three Modules with one motor & 4 rafters

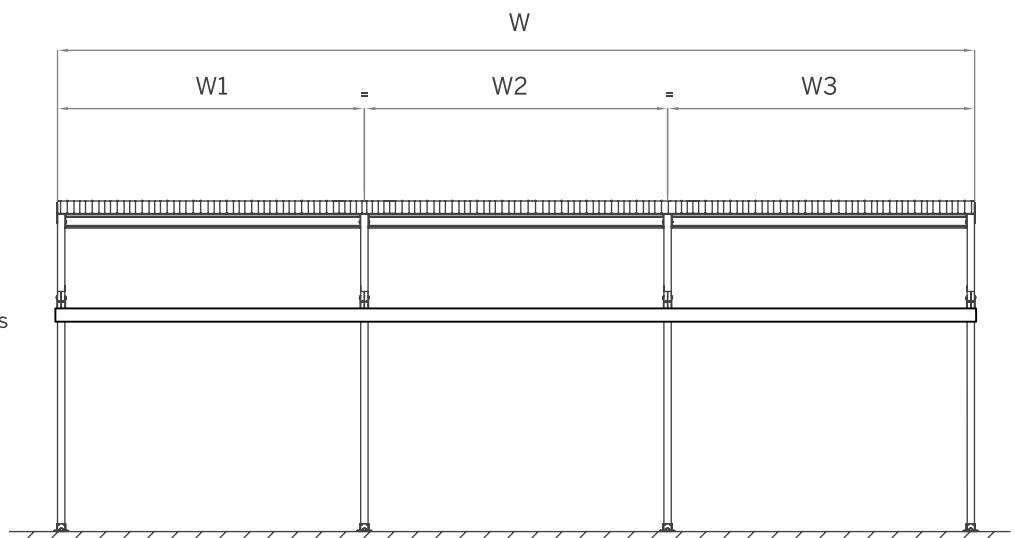

Company Name:  
Order Reference:

Order Date:  
Quantity:

## DIMENSIONS

W - Total Width .....cm  
P - Projection.....cm  
C - Wall / Back Height.....cm  
H - Front / Post Height.....cm  
Total Number of Posts Required .....  
(Maximum span between posts with gutter profile is 600cm)

If modules are multiple and each module is in different width, please provide details (max. width for single module is 450cm, double modules 900cm, triple modules 1300cm)

W 1 .....cm

W 2 .....cm

W 3 .....cm

## POWDERCOAT COLORS

| RAL colors                        | Exclusive colors               | Texture colors                  |                                   |
|-----------------------------------|--------------------------------|---------------------------------|-----------------------------------|
| <input type="checkbox"/> RAL 9016 | <input type="checkbox"/> OGN35 | <input type="checkbox"/> ST9010 | <input type="checkbox"/> Other... |
| <input type="checkbox"/> RAL 1013 | <input type="checkbox"/> OS561 | <input type="checkbox"/> ST9001 |                                   |
| <input type="checkbox"/> RAL 9006 | <input type="checkbox"/> OY395 | <input type="checkbox"/> ST1013 |                                   |
| <input type="checkbox"/> RAL 7006 | <input type="checkbox"/> OGN39 | <input type="checkbox"/> ST7039 |                                   |
| <input type="checkbox"/> RAL 7016 | <input type="checkbox"/> ON617 | <input type="checkbox"/> ST7016 |                                   |
| <input type="checkbox"/> RAL 9005 | <input type="checkbox"/> ON611 | <input type="checkbox"/> ST8019 |                                   |

## FABRIC

| Basic                                  | Semi Transparent                           |                                   |
|--|--|-----------------------------------|
| <input type="checkbox"/> WT785 / White | <input type="checkbox"/> STRW22 / White    | <input type="checkbox"/> Other... |
| <input type="checkbox"/> CR295 / Cream | <input type="checkbox"/> STRB33 / Black    |                                   |
| Xclusive                               | Matt                                       |                                   |
| <input type="checkbox"/> WTEX / White  | <input type="checkbox"/> MW23 / White      |                                   |
| <input type="checkbox"/> CRMX / Cream  | <input type="checkbox"/> MC26 / Cappuccino |                                   |
| <input type="checkbox"/> GRYX / Grey   |  |                                   |

## OPTIONALS

- |   |   |
|---|---|
| <input type="checkbox"/> STANDARD High Power Led Lighting                         | <input type="checkbox"/> Supporting Steel Structure With Post   |
| <input type="checkbox"/> HDD LUX High Power Led Lighting                          | <input type="checkbox"/> Supporting Steel Structure With Post (Galvanized)  |
| <input type="checkbox"/> Dimmer Kit   | <input type="checkbox"/> Wall Installation Steel Beam   |
| <input type="checkbox"/> Aerofoil Louvre (Line) .....pc                           | <input type="checkbox"/> Wall Installation Steel Beam (Galvanized)  |
| <input type="checkbox"/> Side Rafter.....cm<br>Quantity.....pc                    | <input type="checkbox"/> Additional Post Of Supporting Steel Structure ..... pc   |
| <input type="checkbox"/> Support Post of Side Rafter..... cm<br>Quantity ..... pc | <input type="checkbox"/> Additional Post Of Supp. Steel Str. (Galvanized) ..... pc  |
| <input type="checkbox"/> Gutter Flush with Rafter (Type B-Flush Finish)           | <input type="checkbox"/> Side Overhang (max. 100cm per side) Type..... ( I / II / III / IV / V / VI )<br>Left Overhang:.....cm Right Overhang:.....cm |
| <input type="checkbox"/> Additional Rail ..... pc                                 | <input type="checkbox"/> Storm Channel for Joining System & Double Rafter Wall<br>Bracket Kit (for Multiple Systems)                                  |

## INSTALLATION BRACKET

Wall Bracket  Ceiling Bracket

## POST INSTALLATION BASE

Type A (Arch Opening)  Type AA (Without Extension)  
 Type B (Spout)  Type BB (Without Extension)  
 Type Hidden

ADDITIONAL NOTES & DRAWINGS ATTACHED